

SHARP SERVICE MANUAL

No. 00ZU270CMUSME

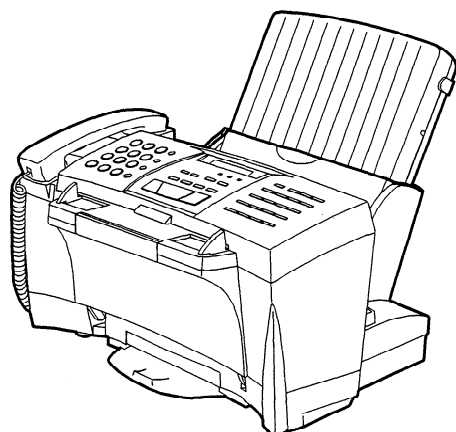

FACSIMILE

UX-2700CM MODEL FO-2550CM

CONTENTS

CHAPTER 1. GENERAL DESCRIPTION

[1] Specifications	1-1
[2] Operation panel	1-2
[3] Transmittable documents	1-3
[4] Installation	1-4
[5] Quick reference guide	1-9

CHAPTER 2. ADJUSTMENTS

[1] Adjustments	2-1
[2] Diagnostics and service soft switch	2-2
[3] Troubleshooting	2-17
[4] Error code table	2-18

CHAPTER 3. MECHANISM BLOCKS

[1] General description	3-1
[2] Disassembly and assembly procedures	3-4

CHAPTER 4. DIAGRAMS

[1] Block diagram	4-1
[2] Wiring diagram	4-2
[3] Point-to-point diagram	4-3

CHAPTER 5. CIRCUIT DESCRIPTION

[1] Circuit description	5-1
[2] Circuit description of control PWB	5-2
[3] Circuit description of TEL/LIU PWB	5-11
[4] Circuit description of power supply PWB	5-14
[5] Circuit description of CIS PWB	5-15
[6] Color scanner block	5-16
[7] Basis of color	5-18

CHAPTER 6. CIRCUIT SCHEMATICS AND PARTS LAYOUT

[1] Control PWB circuit	6-1
[2] TEL/LIU PWB circuit	6-13
[3] Ink sensor PWB circuit	6-15
[4] Printer PWB circuit	6-17
[5] Operation panel PWB circuit	6-23
[6] IrDA PWB circuit	6-24
[7] Power supply PWB circuit	6-25

CHAPTER 7. OPERATION FLOWCHART

[1] Protocol	7-1
[2] Power on sequence	7-2

CHAPTER 8. OTHERS

[1] Service tools	8-1
[2] IC signal name	8-6

CHAPTER 9. INK JET PRINTER

[1] Engine specifications	9-1
[2] Abbreviations	9-1
[3] Diagnostic information	9-1
[4] Circuit description	9-2
[5] Overall troubleshooting of printer PWB	9-7
[6] How to decide the number of the wrong nozzle	9-10
[7] Waveforms	9-12
[8] Service checks	9-15
[9] IC signal name	9-19

PARTS GUIDE

Parts marked with "▲" is important for maintaining the safety of the set. Be sure to replace these parts with specified ones for maintaining the safety and performance of the set.

CAUTION FOR BATTERY REPLACEMENT

- (Danish) **ADVARSEL !**
Lithiumbatteri-Eksplosionsfare ved fejlagtig håndtering.
Udskiftning må kun ske med batteri af samme fabrikat og type.
Levér det brugte batteri tilbage til leverandoren.
- (English) **Caution !**
Danger of explosion if battery is incorrectly replaced.
Replace only with the same or equivalent type
recommended by the equipment manufacturer.
Discard used batteries according to manufacturer's
instructions.
- (Finnish) **VAROITUS**
Paristo voi räjähtää, jos se on virheellisesti asennettu.
Vaihda paristo ainoastaan laitevalmistajan suosittelemaan
tyyppiin. Hävitä käytetty paristo valmistajan ohjeiden
mukaisesti.
- (French) **ATTENTION**
Il y a danger d'explosion s' il y a remplacement incorrect
de la batterie. Remplacer uniquement avec une batterie du
même type ou d'un type recommandé par le constructeur.
Mettre au rebut les batteries usagées conformément aux
instructions du fabricant.
- (Swedish) **VARNING**
Explosionsfare vid felaktigt batteribyte.
Använd samma batterityp eller en ekvivalent
typ som rekommenderas av apparattillverkaren.
Kassera använt batteri enligt fabrikantens
instruktion.
- (German) **Achtung**
Explosionsgefahr bei Verwendung inkorrektter Batterien.
Als Ersatzbatterien dürfen nur Batterien vom gleichen Typ oder
vom Hersteller empfohlene Batterien verwendet werden.
Entsorgung der gebrauchten Batterien nur nach den vom
Hersteller angegebenen Anweisungen.

CHAPTER 1. GENERAL DESCRIPTION

[1] Specifications

Printing specifications

Print cartridges	Color: Sharp UX-27CC Black: Sharp UX-22BC
Print resolution	High: 600 x 600 dpi (both color and black) Normal: 300 x 300 dpi
Print speed	Color: Up to 2 pages per minute Black: Up to 3 pages per minute
Paper types	Index cards, envelopes, labels, transparencies, glossy film, greeting cards, iron-on transfers, plain, coated, and glossy paper.

Fax specifications

Automatic dialing	Rapid Key Dialing: 38 numbers Speed Dialing: 61 numbers
Memory size*	512 KB (approx. 42 average pages)
Automatic document feeder	20 sheets max.
Modem speed	14400 bps with automatic fallback to 12000, 9600, 7200, 4800, or 2400 bps
Transmission time*	Approx. 6 seconds (Sharp special mode)
Display	16-digit LCD display
Reception modes	Auto/Manual

Resolution	Horizontal: 200 pels/inch Vertical: Standard: 100 lines/inch Fine /Halftone: 200 lines/inch Super fine (transmission only): 400 lines/inch
-------------------	---

Halftone (grayscale)	64 levels
Applicable telephone line	Public switched telephone network
Compatibility	ITU-T (CCITT) G3 mode
Configuration	Half-duplex, desktop transceiver
Compression scheme	MH, MR, MMR
Scanning method	Sheet-feeder CIS (Contact Image Sensor)
Effective printing width	8" (203 mm) max.
Paper margins	Top: 5.5 mm Bottom: 23.7 mm
Input document size	Automatic feeding: Width: 5.8 to 8.5" (148 to 216 mm) Length: 5.5 to 11" (140 to 279 mm) Manual feeding: Width: 5.8 to 8.5" (148 to 216 mm) Length: 5.5 to 39.4" (140 to 1000 mm)
Effective scanning width	8.3" (210 mm) max.
Contrast control	Automatic/Dark selectable

NOTE: The Sharp Color MFP is not able to send or receive color faxes.

Copying specifications

Resolution	300 dpi
Multiple copies	Up to 99 (monochrome copying only)
Copy reduction/enlargement	Monochrome: 50%, 75%, 120%, 150% Color: 50%, 200%

PC scanning specifications

Resolution	Enhanced 600 dpi
Scanning modes	Color/monochrome/grayscale(64 levels)

General specifications

Power requirements	120 V AC, 60 Hz
Operating temperature	50 to 100°F (10 to 35°C)
Operating humidity	30 - 80%RH
Power consumption	Stand-by: 8.5 W Maximum: 40 W
Dimensions	Width: 16.0" (406 mm) Depth: 12.0" (306 mm) Height: 10.0" (255 mm) (Without attachments)
Weight	Approx. 13.0 lbs. (5.9 kg) (without attachments)

* Based on ITU-T Test Chart #1 at standard resolution in Sharp special mode, excluding time for protocol signals (i.e., ITU-T phase C time only).

As a part of our policy of continuous improvement, SHARP reserves the right to make design and specification changes for product improvement without prior notice. The performance specifications figures indicated are nominal values of production units. There may be some deviation from these values in individual units.

[2] Operation panel

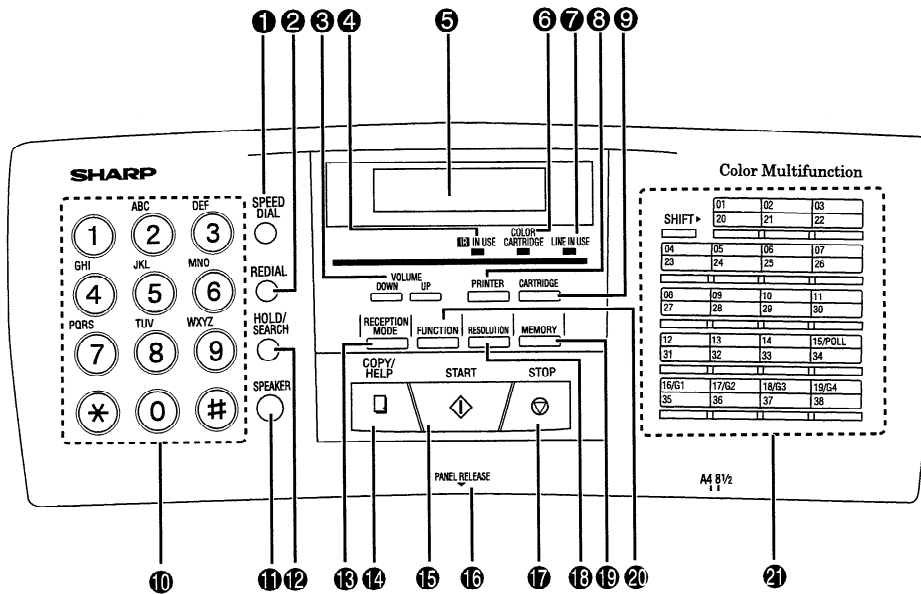

- 1 SPEED DIAL key**
Press this key to dial a 2-digit Speed Dial number.
- 2 REDIAL key**
Press this key to automatically redial the last number dialed.
- 3 VOLUME keys**
Press these keys to adjust the volume of the handset when the handset is lifted, the volume of the speaker when the **SPEAKER** key has been pressed, or the volume of the ringer at all other times.
- 4 IR IN USE light**
This blinks while the Sharp Color MFP is receiving data by infrared transmission from a notebook computer, digital camera, or Zaurus.
- 5 Display**
This displays messages and prompts during operation and programming.
- 6 COLOR CARTRIDGE light**
This lights when a color print cartridge is installed. Faxes are received to memory when this light is on.
- 7 LINE IN USE light**
This lights while the Sharp Color MFP is using the telephone line.
- 8 PRINTER key**
Press this key to eject paper from the machine, or reset the machine after clearing a paper jam or other printer error.
- 9 CARTRIDGE key**
Press this key to change a print cartridge or install a new print cartridge.
- 10 Number keys**
Use these keys to dial numbers, and enter numbers and letters during number/name storing procedures.
- 11 SPEAKER key**
Press this key to hear the line and fax tones through the speaker when sending a document.
Note: This is not a speakerphone . You must pick up the handset to talk with the other party.
- 12 HOLD/SEARCH key**
Press this key to search for an automatic dialing number, or, during a phone conversation, press this key to put the other party on hold.
- 13 RECEPTION MODE key**
Press this key to select the reception mode. The selected mode will appear in the display.
- 14 COPY/HELP key**
When a document is in the feeder, press this key to make a copy. At any other time, press this key to print out the Help List, a quick reference guide to the operation of your fax.
- 15 START key**
Press this key to send or receive a document.
- 16 PANEL RELEASE**
Pull this release up to open the operation panel.
- 17 STOP key**
Press this key to stop operations before they are completed.
- 18 RESOLUTION key**
Press this key to adjust the resolution and contrast before sending or copying a document.
- 19 MEMORY key**
Press this key to scan a document into memory before transmitting it.
- 20 FUNCTION key**
Press this key to select various special functions.
- 21 Rapid Dial Keys**
Press one of these keys to dial a fax or voice number automatically. To dial the bottom number on a Rapid Key, press the **SHIFT** key before pressing the Rapid Key. (Note that you must attach the Rapid Key labels.)

[3] Transmittable documents

1. Document Sizes

Normal size	width	5.83"-8.5"(148 – 216 mm)
	length	5.04"-11"(128 – 297 mm)

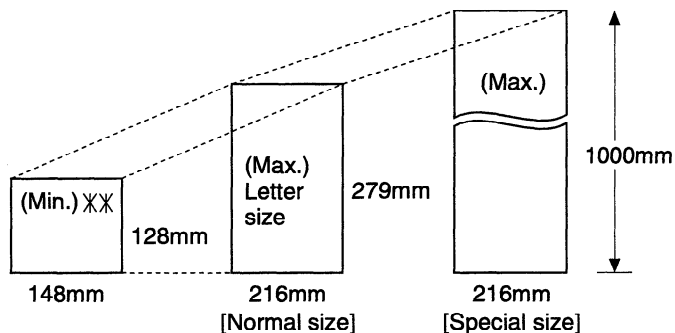

XX Use document carrier sheet for smaller documents.

* With special sizes, only one sheet can be fed into the machine at a time. Insert next page into feeder as current page is being scanned.

2. Paper Thickness & Weight

Normal size	ADF 10 sheets	Thickness	$2.4 \times 10^{-3} - 4.7 \times 10^{-3}$ inch (0.06–0.12 mm)
		Weight	0.15×10^{-3} lbs/inch ² (52–104g/ m ²) (14–28 lbs)
	ADF 20 sheets	Thickness	$2.4 \times 10^{-3} - 3.5 \times 10^{-3}$ inch (0.06–0.09 mm)
		Weight	$0.77 \times 10^{-3} - 0.11 \times 10^{-3}$ inch (52–74.3g/ m ²) (14–20 lbs)
Special size	Thickness	$4.7 \times 10^{-3} - 7.9 \times 10^{-3}$ inch (0.12–0.20 mm)	
	Weight	$0.15 \times 10^{-3} - 0.20 \times 10^{-3}$ lbs/inch ² (52–157g/ m ²)	

3. Document Types

- Normal paper
Documents handwritten in pencil (No. 2 lead or softer), fountain pen, ball-point pen, or felt-tipped pen can be transmitted.
Documents of normal contrast duplicated by a copying machine can also be transmitted.
- Diazo copy (blue print)
Diazo copy documents of a normal contrast may be transmitted.
- Carbon copy
A carbon copy may be transmitted if its contrast is normal.

4. Cautions on Transmitting Documents

- Documents written in yellow, greenish yellow, or light blue ink cannot be transmitted.
- Ink, glue, and correcting fluid on documents must be dry before the documents can be transmitted.
- All clips, staples and pins must be removed from documents before transmission.
- Patched (taped) documents should be copied first on a copier and then the copies used for transmission.
- All documents should be fanned before insertion into the feeder to prevent possible double feeds.

5. Automatic Document Feeder Capacity

Number of pages that can be placed into the feeder at anytime is as follows:

Normal size: max. ADF 20 sheets (14 lbs – 20 lbs)

Special size: single sheet only (manual feed)

- NOTES:
- When you need to send or copy more pages than the feeder limit, place additional pages in feeder when last page in feeder is being scanned.
 - Place additional pages carefully and gently in feeder. If force is used, double-feeding or a document jam may result.

6. Readable Width & Length

The readable width and length of a document are slightly smaller than the actual document size.

Note that characters or graphics outside the effective document scanning range will not be read.

- **Readable width**

210 mm, max.

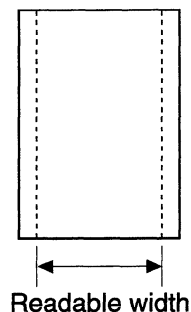

- **Readable length**

This is the length of the document sent minus 0.16" (4 mm) from the top and bottom edges.

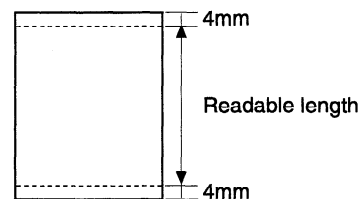

7. Use of Document Carrier Sheet

A document carrier sheet must be used for the following documents.

- Those with tears.
- Those smaller than size 5.83"(W) x 5.04"(L) (148 mm (W) x 128 mm (L)).
- Carbon-backed documents

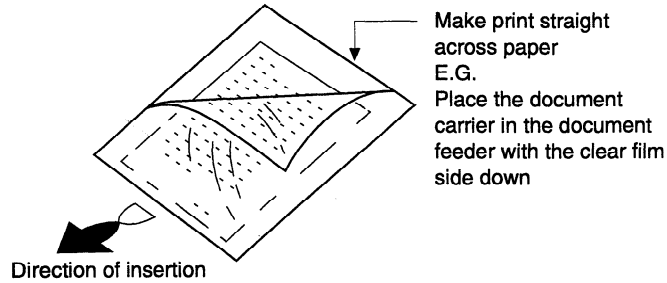

NOTE: To transmit a carbon-backed document, insert a white sheet of paper between the carbon back of the document and the document carrier.

- Those containing an easily separable writing substance (e.g., tracing paper written on with a soft, heavy lead pencil).

NOTES:

- When using the document carrier, carefully read the instructions written on the back.

- If the document carrier is dirty, clean it with a soft, moist cloth, and then dry it before using for transmission.
- Do not place more than one document in the carrier at a time.

[4] Installation

1. Site selection

Take the following points into consideration when selecting a site for this model.

ENVIRONMENT

- The machine must be installed on a level surface.
- Keep the machine away from air conditioners, heaters, direct sunlight, and dust.
- Provide easy access to the front, back, and sides of the machine. In particular, keep the area in front of the machine clear, or the original document may jam as it comes out after scanning.
- The temperature should be between 5° and 35°C.
- The humidity should be between 30% and 85% (without condensation).

ELECTRICITY

120V , 60Hz, grounded (3-prong) AC outlet is required.

Caution!

- Connection to a power source other than that specified will cause damage to the equipment and is not covered under the warranty.
- If your area experiences a high incidence of lightning or power surges, we recommend that you install a surge protector for the power and telephone lines. Surge protectors can be purchased at most telephone specialty stores.

If the machine is moved from a cold to a warm place...

If the machine is moved from a cold to a warm place, it is possible that the reading glass may fog up, preventing proper scanning of documents for transmission. To remove the fog, turn on the power and wait approximately 2 hours before using the machine.

TELEPHONE JACK

A standard RJ11C telephone jack must be located near the machine. This is the telephone jack commonly used in most homes and offices.

- Plugging the fax machine into a jack which is not an RJ11C jack may result in damage to the machine or your telephone system. If you do not know what kind of jack you have, or needed to have one installed, contact the telephone company.

2. Trays

- ① Attach the document tray.

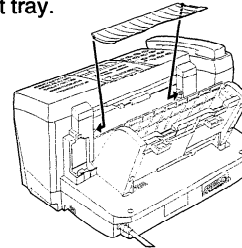

- ② Insert the paper tray into the back of the machine as shown.

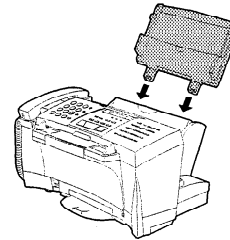

- ③ Pull out the original document support and the output tray.

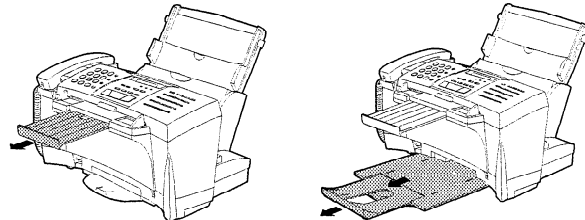

Note: When receiving faxes, copying or printing, do not let a large number of pages accumulate in the output tray. This may obstruct the outlet and cause paper jams.

3. Connections

① Handset

Connect the handset as shown and place it on the handset rest.

- ◆ The ends of the handset cord are identical, so they will go into either jack.

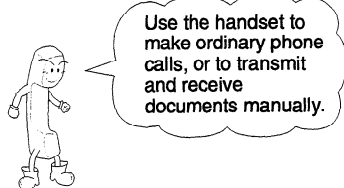
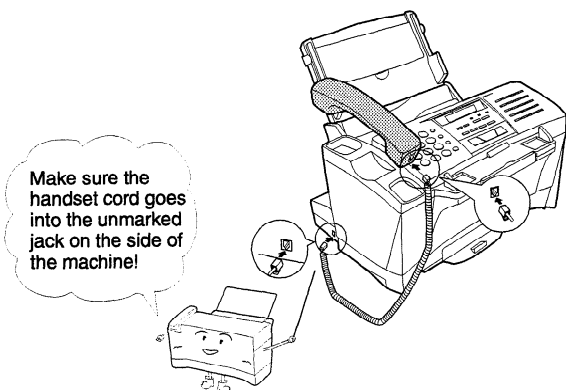

② Power cord

Plug the power cord into a 120 V, 60 Hz, grounded (3-prong) AC outlet.

Caution!

Do not plug the power cord into any other kind of outlet. This will damage the machine and is not covered under the warranty.

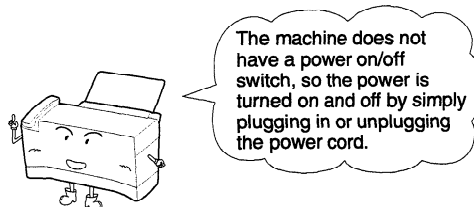
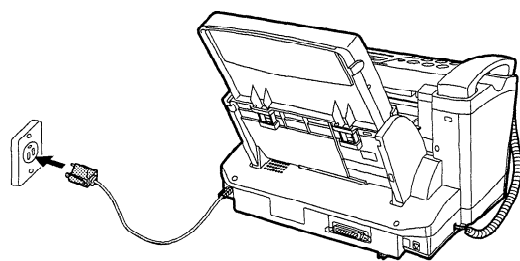

Note: If your area experiences a high incidence of lightning or power surges, we recommend that you install surge protectors for the power and telephone lines. Surge protectors can be purchased at most telephone specialty stores.

③ Telephone line cord

Insert one end of the line cord into the jack on the back of the machine marked **TEL. LINE**. Insert the other end into a standard (RJ11C) single-line wall telephone jack.

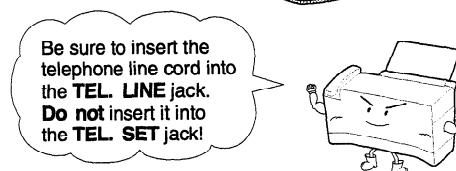
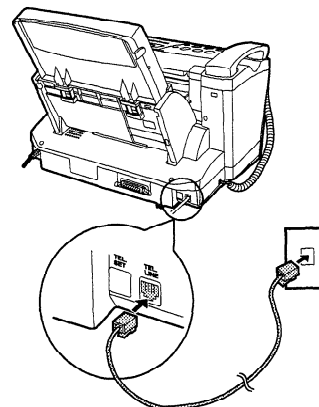

Note: The Sharp MFP is set for touch-tone dialing. If you are on a pulse dial (rotary) line, you must set the Sharp MFP for pulse dialing. Press the following keys on the operation panel:



4. Installing a Print Cartridge

Your Sharp Color MFP uses either a **UX-27CC** color print cartridge or a **UX-22BC** black print cartridge.



We recommend that you keep a black cartridge installed for normal use, and change to a color cartridge only when you need to print a color job.

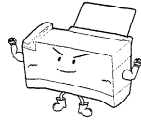

Note: If you receive a fax when a color print cartridge is installed, the fax will be held in memory and printed out when a black cartridge is installed.

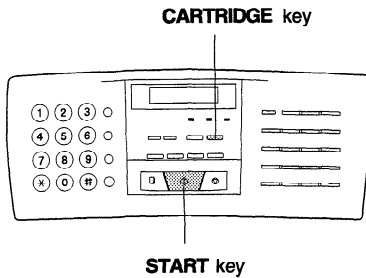

- ① Press the **CARTRIDGE** key.



- The cartridge carrier will move to the center of the print compartment.

- ② Open the front cover of the Sharp Color MFP.

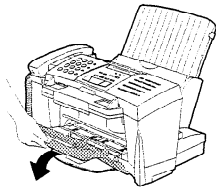

Note on changing cartridges:
When you need to change a print cartridge, remove the currently installed cartridge after Step 2 above. Remove the cartridge by pulling the knob on the cartridge toward you until you hear a click.

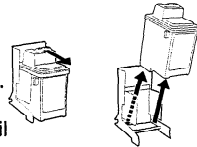

If the cartridge is still useable, insert it into the cartridge holder on the back of the machine. Push back on the cartridge until it snaps into place.

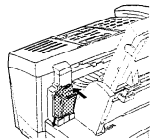

- To prevent the used print cartridge from drying out, be sure to store it in the cartridge holder.

- ③ Remove the new print cartridge from its packaging.

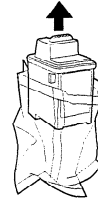

- ④ Gently remove the sticker and transparent tape covering the copper printhead.

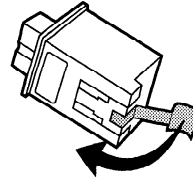

Do not touch the copper contact area!

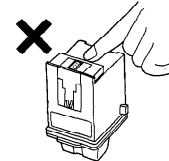

- ⑤ Insert the print cartridge into the cartridge carrier. Push back on the cartridge until it snaps into place.

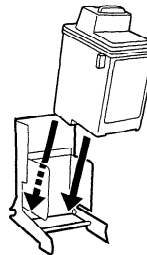

Note: If the print cartridge moves loosely in the carrier, it is not locked into place. Repeat this step.

- ⑥ Close the front cover.

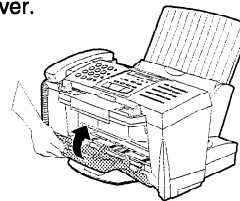

- ⑦ Press the **START** key.



The display on the Sharp Color MFP will show:

SELECT CARTRIDGE

Press 1 if you installed a new cartridge, or 2 if you installed an old cartridge.

- ⑧ Press the **3** key if you installed a new black cartridge, or the **4** key if you installed a new color cartridge. (When installing a previously used cartridge, press the 1 key for a used black cartridge or the 2 key for a used color cartridge.)

NEW BLACK CART. NEW COLOR CART.

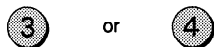

• The cartridge will return to its home position. If you pressed 3 or 4 for a new cartridge, the Sharp MFP will print a test page for printhead alignment.

- ⑨ If you installed a new print cartridge, look at the test page and locate the line that comes closest to forming a perfectly straight line.

In this example, line 13 comes closest to forming a straight line.

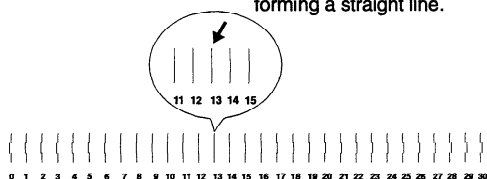

- ⑩ Press these keys on the Sharp MFP:



The display will show: ALIGN CARTRIDGE
ENTER (00-30) 15
START: PRINT

- ⑪ Enter the two-digit number of the straightest line on the test page. (If the number is less than 10, enter a 0 before the number.)

Example: Line 13 1 3

The display will show: CLEAN NOZZLES

- ⑫ Press the **STOP** key to return to the time and date display.



Note: If you have installed a color cartridge, the display will show the following alternating messages:

COLOR CARTRIDGE!

USE BLACK FOR RX

5. Loading Printing Paper

You can load letter or legal size paper in the paper tray. The maximum number of sheets is:

- ◆ 200 for paper from 16 to 20 lbs. (60 to 80 g/m²)
- ◆ 150 for paper from 20 to 24 lbs. (90 g/m²) (such as coated paper)

- ① Remove the paper cover if it is on the paper tray.

- If you are going to load legal size paper, flip up the paper tray extender.

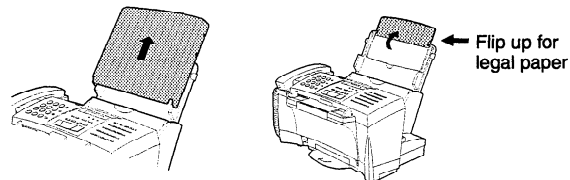

- ② Fan the paper, and then tap the edge against a flat surface to even the stack.

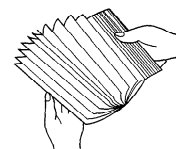

- ③ Pull the paper release plate toward you.

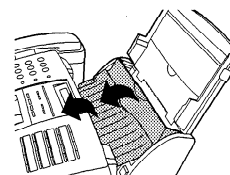

- ④ Insert the stack of paper into the tray, **print side up**

- If paper remains in the tray, take it out and combine it into a single stack with the new paper before adding the new paper.

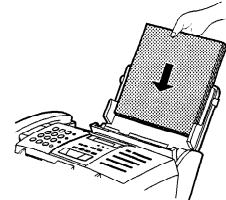

- ⑤ Replace the paper cover on the paper tray.

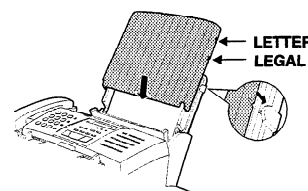

- ⑥ Push the paper release plate back down.

- **Important** Be sure to replace the paper cover **before** you push the paper release plate down.

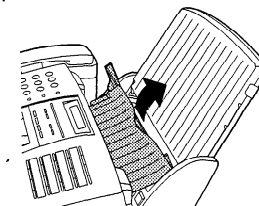

- ⑦ The Sharp Color MFP has been set at the factory to scale the size of received faxes to letter size paper. If you have loaded legal paper, you must change the paper size setting to legal. Press these keys:



The display will show: PAPER SIZE

Press 1 to select LETTER, 2 to select LEGAL, or 3 to select A4.

LETTER: ①

LEGAL: ②

A4: ③

Press the **STOP** key to return to the date and time display.



Note: This setting is only for received faxes. To set the paper size for printing from your computer, see your online Operation Guide.

- ⑧ The Sharp Color MFP has been set at the factory to print on plain paper. If you have loaded coated paper, you must change the media type setting to COATED. Press these keys:



The display will show: MEDIA TYPE

Press 1 to select PLAIN or 2 to select COATED.

PLAIN COATED

① or ②

Press the **STOP** key to return to the date and time display.



6. Clearing Paper Jams

Clearing a jammed document

If the original document doesn't feed properly during transmission or copying, or **DOCUMENT JAMMED** appears in the display, first try pressing the **START** key. If the document doesn't feed out, open the operation panel and remove it.

Important

Do not try to remove a document without opening the operation panel. This may damage the feeder mechanism.

- ① Pull the release marked **PANEL RELEASE** up and open the operation panel.

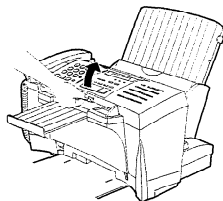

- ② Remove the document.

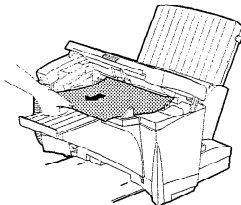

- ③ Close the operation panel, making sure it clicks into place.

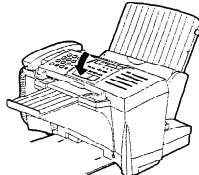

Clearing jammed printing paper

- ① Open the front cover of the Sharp MFP.

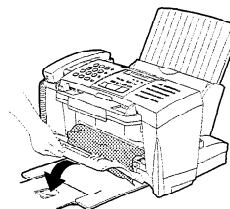

- ② Grasp the leading edge of the jammed paper and pull it out of the machine.

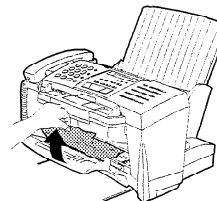

- ③ If it is too difficult to pull the jammed paper out from the front of the machine, remove the paper tray cover, pull the paper release plate toward you, and pull the jammed paper out from the back of the machine.

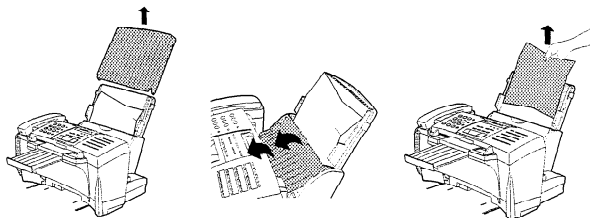

- ④ Make sure there are no torn pieces of paper remaining in the machine.

- ⑤ Close the front cover. Replace the paper tray cover (if removed), and then press the paper release plate back down.

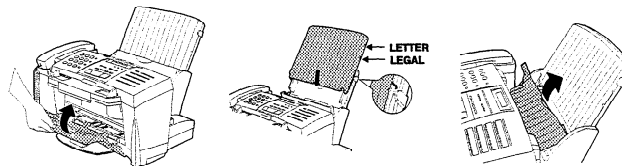



- ⑥ Press the **PRINTER** key to reset the Sharp MFP.

PRINTER



[5] Quick reference guide

CHANGING PRINT CARTRIDGES

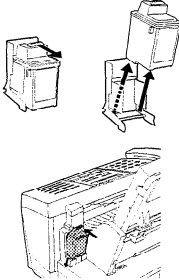
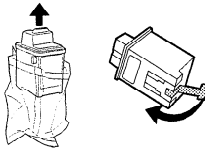
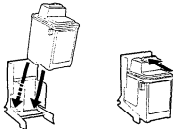
- Press: 
- Open the front cover of the Sharp Color MFP. 
- Remove the current print cartridge.
 - If the cartridge is still useable, insert it in the holder on the back of the machine. Push back on the cartridge until it snaps into place. 
- If you are installing a new print cartridge, remove the cartridge from its packaging. Remove the sticker and tape from the cartridge. 
- Insert the print cartridge into the cartridge carrier. Push back until it snaps into place. 
- Close the front cover
- Enter a number to set the cartridge type:
 - 1: Old black cartridge
 - 2: Old color cartridge
 - 3: New black cartridge
 - 4: New color cartridge
 - If you pressed 3 or 4 for a new cartridge, the Sharp MFP will print a test page for printhead alignment.
- If you installed a new print cartridge, press:

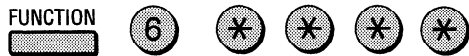





Display shows:

ALIGN CARTRIDGE

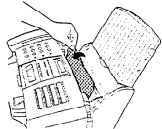
- Enter the two-digit number of the straightest line on the test page.
- Press: 

MAKING COPIES

- If you are copying onto a transparency or special paper, flip up the document tray and insert the media into the manual paper feeder. Make sure the display shows:
 - CHECK MAN FEEDER
 - USE AUTO FOR RX

- Place the document (up to 20 pages) face down in the document feeder. 
- Press: 
- Press 1 to use the preset copy settings, or 2 (MANU) to select each setting individually. (If you are making a color copy and selected 1, copying will begin. If you selected 2, go to Step 6.
- If you are making one copy per original, press the **START** key. If you are making multiple copies per original, enter the number of copies per original (if the number is less than 10, enter a "0" before the number).
 - If you selected PRESET in Step 4, go to Step 10.
- Enter a number for the size of the print media:
 - 1: LETTER
 - 2: LEGAL
 - 3: A4
- Enter a number to select reduction/enlargement.

Black/white copy	Color copy
1: AUTO	1: 50%
2: 50%	2: 100%
3: 75%	3: 200%
4: 100%	
5: 120%	
6: 150%	
- Select the type of media to be used:
 - 1: PLAIN PAPER
 - 2: COATED PAPER
 - 3: TRANSPARENCY
 - 4: GLOSSY PAPER

(Note: Setting 3 and 4 only appears if you inserted a sheet of media in the manual feeder.)

 - If you are making a color copy, go to Step 11.
- Select the copy print quality. Press 1 for NORMAL or 2 for DRAFT.
- If desired, press the **RESOLUTION** key to adjust the resolution and/or contrast.
- Press **START** to begin copying. 

STORING AND CLEARING NUMBERS FOR AUTO DIALING

1. Press: **FUNCTION** **3** **#**

Display shows: **FAX/TEL # MODE**

- Press **1** to store a number or **2** to clear a number.
- Enter a 2-digit Speed Dial number (from 01 to 38 for Rapid Key Dialing, or 39 to 99 for Speed Dialing). (If you are clearing a number, go to Step 7.)

4. Enter the full telephone/fax number.

5. Press: **START**

6. Enter the name of the location by pressing number keys as shown below (max. of 20 characters).

- To enter two letters in succession that require the same key, press the **SPEAKER** key after entering the first letter.

A = 2 2	J = 5 5	T = 8 8
B = 2 2 2 2	K = 5 5 5	U = 8 8 8
C = 2 2 2 2 2	L = 5 5 5 5	V = 8 8 8 8
D = 3 3	M = 6 6	W = 9 9
E = 3 3 3	N = 6 6 6	X = 9 9 9
F = 3 3 3 3	O = 6 6 6 6	Y = 9 9 9 9
G = 4 4	P = 7 7	Z = 9 9 9 9 9
H = 4 4 4	Q = 7 7 7	SPACE = 1 1
I = 4 4 4 4	R = 7 7 7 7	
	S = 7 7 7 7 7	

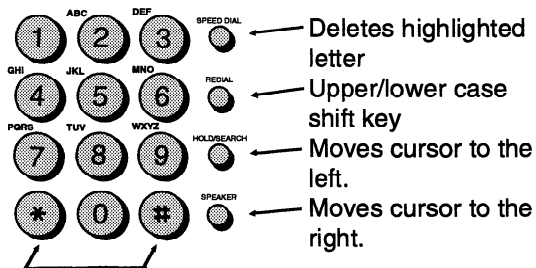

Press either key one or more times to select and enter a symbol.

7. Press: **START** **STOP**

SENDING DOCUMENTS

Place the document (up to 20 pages) face down in the document feeder.



Normal Dialing

- Lift the handset or press **SPEAKER**.
- Dial the fax number.
- Wait for the reception tone (if a person answers, ask them to press their Start key).
- Press: **START**

Rapid Key Dialing

Press the appropriate Rapid Key (if the Rapid Key is from 20 to 38, press the **SHIFT** key first). Transmission will begin automatically.

Speed Dialing

- Press: **SPEED DIAL**
- Enter 2-digit Speed Dial number.
- Press: **START**

RECEIVING DOCUMENTS

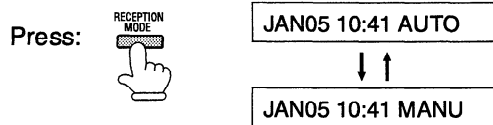

AUTO mode: The fax automatically answers on four rings and receives the incoming document.

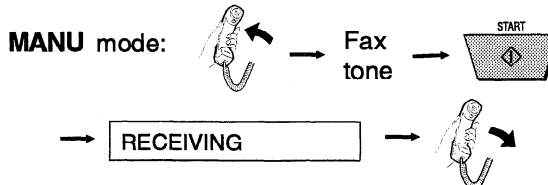

Selecting the receiving unit

- Press: **FUNCTION** **#**
- Press **1** for fax reception to the Sharp MFP, or **2** for fax reception to your computer.

Note: For your computer to receive faxes automatically, the Color MFP reception mode must be set to AUTO.